

# ROYALOHM

## SPECIFICATION FOR APPROVAL

### TRELIK

Description : Metal Film Fixed Resistors

Royalohm Part no.: MFF04FFxxxxA50 (MF 0.4W-SS +/- 1% 50ppm)

Approved by

**Parts corresponding to RoHS Compliant: 2005-Apr.-1**

Royal Electronic Factory (Thailand) Co., Ltd.

20/1-2 Moo 2 Klong-Na, Muang

Chachoengsao 24000, Thailand

Tel: +66-38-822404-8

Fax: +66 38-981190 / 823765

E-mail Address: Export sales: [Export@royalohm.com](mailto:Export@royalohm.com)

Local sales: [Local@royalohm.com](mailto:Local@royalohm.com)

<http://www.royalohm.com>

P.O. Box 251 Klongchan, Bangkok 10240, Thailand

Approved	Checked	Prepared
Mr. Jack Lin	Ms. S. Sakultala	Ms. I. Supakhinee

Issued Date: 2007/09/25



## 1. Scope:

This specification for approval relates to Metal Film Fixed Resistors manufactured by ROYALOHM 's specifications.

## 2. Type designation:

The type designation shall be in the following form :

(Ex.)	MF	0.4W-SS	F	22KΩ
	Type	Power Rating	Resistance Tolerance	Nominal Resistance

## 3. Ratings:

Ratings shall be shown in the table 1.

Table 1

Type	MF
Rated Power	0.4W-SS at 70°C
Max. Working Voltage	200V
Max. Overload Voltage	400 V
Dielectric Withstanding Voltage	200 V
Rated Ambient Temp.	70 °C
Operating Temp. Range	-55°C --- +155°C
Resistance Tolerance	± 1%
Resistance Range	10Ω----1MΩ

## 3.1 Power rating:

Resistors shall have a power rating based on continuous full load operation at an ambient temperature of 70 °C. For temperature in excess of 70 °C , the load shall be derated as shown in the figure 1.

## 3.2 Voltage rating:

Resistors shall have a rated direct-current (DC) continuous working voltage or an approximate sine-wave root-mean-square (RMS) alternating-current (AC) continuous working voltage at commercial-line frequency and waveform corresponding to the power rating , as determined from the following formula :

$$RCWV = \sqrt{P \times R}$$

Were : RCWV = Rated DC or RMS AC continuous working voltage at commercial-line frequency and waveform (volt)

P = Power Rating (watt)

R = Nominal Resistance (ohm)

## Metal Film Fixed Resistors

In no case shall the rated DC or RMS AC continuous working voltage be greater than the applicable maximum value

Figure 1.

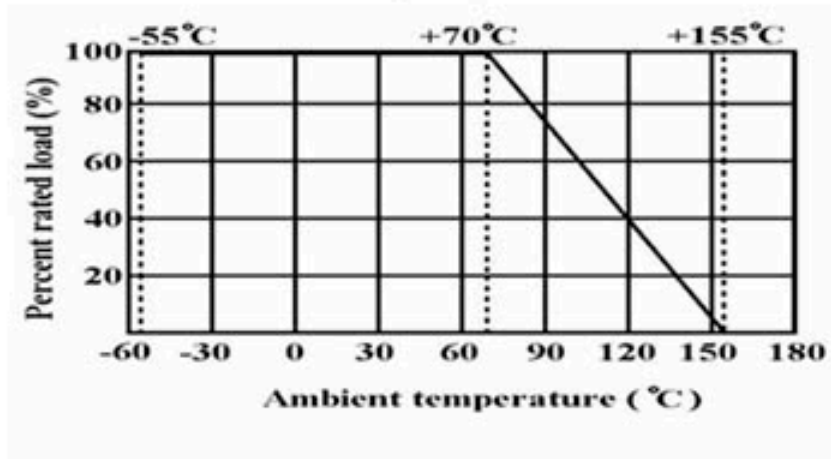

### 3.3 Nominal resistance :

Effective figures of nominal resistance shall be in accordance with E-96 series, and resistance tolerance shall be shown by table 1.

### 4. Construction :

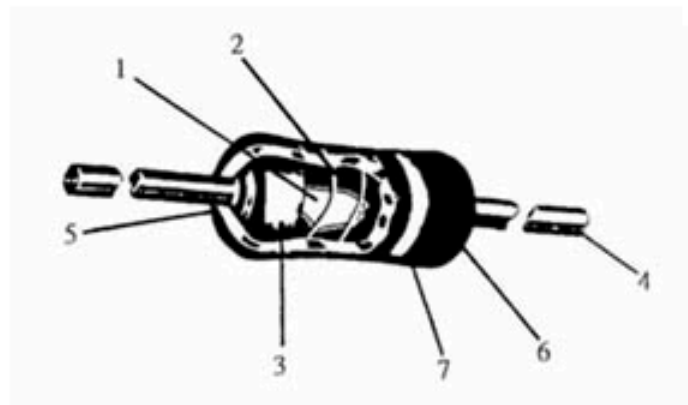

No.	Name	Material
1	Basic Body	Rod Type Ceramics
2	Resistance Film	Metal Film
3	End Cap	Steel (Tin plated iron surface)
4	Lead Wire	Annealed copper wire coated with tin
5	Joint	By Welding
6	Coating	Insulated & Non-Flame Paint ( Color : Green Meeting U L 94 V O Standard )
7	Color Code	Non-Flame Paint Epoxy Resin

## Metal Film Fixed Resistors

### 5. Characteristics :

Characteristics	Limits	Test Methods ( JIS C 5201-1 )
DC. Resistance	Must be within the specified tolerance	5.1 The limit of error of measuring apparatus shall not exceed allowable range or 1% of resistance tolerance
Temperature coefficient	Within the temperature coefficient specified below : ± 50PPM/°C Max.	5.2 Natural resistance change per temp. degree centigrade $\frac{R_2 - R_1}{R_1(t_2 - t_1)} \times 10^6 \text{ (PPM/°C)}$ R1: Resistance value at room temperature (t1) R2: Resistance value at room temp. plus 100 °C (t2)
Short time overload	Resistance change rate is ± (0.5% + 0.05 Ω) Max. with no evidence of mechanical damage	5.5 Permanent resistance change after the application of a potential of 2.5 times RCWV for 5 seconds
Dielectric withstanding voltage	No evidence of flashover mechanical damage, arcing or insulation break down	5.7 Resistors shall be clamped in the trough of a 90° metallic V-block and shall be tested at AC potential respectively specified in the table 1.
Pulse overload	Resistance change rate is ± (1% + 0.05 Ω) Max. with no evidence of mechanical damage	5.8 Resistance change after 10,000 cycles (1 sec. "on" , 25 secs. "off" ) at 4 times RCWV
Terminal strength	No evidence of mechanical damage	6.1 <b>Direct load :</b> Resistance to a 2.5 kgs direct load for 10 secs. in the direction of the longitudinal axis of the terminal leads <b>Twist test :</b> Terminal leads shall be bent through 90 ° at a point of about 6mm from the body of the resistor and shall be rotated through 360° about the original axis of the bent terminal in alternating direction for a total of 3 rotations
Resistance to soldering heat	Resistance change rate is ± (1% + 0.05 Ω) Max. with no evidence of mechanical damage	6.4 Permanent resistance change when leads immersed to 3.2 to 4.8 mm from the body in 350°C ± 10 °C solder for 3 ± 0.5 seconds

## Metal Film Fixed Resistors

Characteristics	Limits	Test Methods ( JIS C 5201-1 )															
Solderability	95 % coverage Min.	6.5 The area covered with a new, smooth, clean, shiny and continuous surface free from concentrated pinholes. Test temp. of solder : $245^{\circ}\text{C} \pm 3^{\circ}\text{C}$ Dwell time in solder : 2 ~ 3 seconds															
Resistance to solvent	No deterioration of protective coatings and markings	6.9 Specimens shall be immersed in bath of trichroethane completely for 3 mins. with ultrasonic															
Temperature cycling	Resistance change rate is $\pm (1\% + 0.05\Omega)$ Max. with no evidence of mechanical damage	7.4 Resistance change after continuous 5 cycles for duty shown below: <table border="1" style="margin-left: auto; margin-right: auto;"> <thead> <tr> <th style="text-align: center;">Step</th> <th style="text-align: center;">Temperature</th> <th style="text-align: center;">Time</th> </tr> </thead> <tbody> <tr> <td style="text-align: center;">1</td> <td style="text-align: center;"><math>-55^{\circ}\text{C} \pm 3^{\circ}\text{C}</math></td> <td style="text-align: center;">30 mins</td> </tr> <tr> <td style="text-align: center;">2</td> <td style="text-align: center;">Room temp.</td> <td style="text-align: center;">10 ~ 15 mins</td> </tr> <tr> <td style="text-align: center;">3</td> <td style="text-align: center;"><math>+155^{\circ}\text{C} \pm 2^{\circ}\text{C}</math></td> <td style="text-align: center;">30 mins</td> </tr> <tr> <td style="text-align: center;">4</td> <td style="text-align: center;">Room temp.</td> <td style="text-align: center;">10 ~ 15 mins</td> </tr> </tbody> </table>	Step	Temperature	Time	1	$-55^{\circ}\text{C} \pm 3^{\circ}\text{C}$	30 mins	2	Room temp.	10 ~ 15 mins	3	$+155^{\circ}\text{C} \pm 2^{\circ}\text{C}$	30 mins	4	Room temp.	10 ~ 15 mins
Step	Temperature	Time															
1	$-55^{\circ}\text{C} \pm 3^{\circ}\text{C}$	30 mins															
2	Room temp.	10 ~ 15 mins															
3	$+155^{\circ}\text{C} \pm 2^{\circ}\text{C}$	30 mins															
4	Room temp.	10 ~ 15 mins															
Load life in humidity	<table border="1" style="width: 100%;"> <thead> <tr> <th style="text-align: center;">Resistance value</th> <th style="text-align: center;"><math>\Delta R/R</math></th> </tr> </thead> <tbody> <tr> <td style="text-align: center;">Non-flame type</td> <td style="text-align: center;"><math>\pm 5\%</math></td> </tr> </tbody> </table>	Resistance value	$\Delta R/R$	Non-flame type	$\pm 5\%$	7.9 Resistance change after 1,000 hours (1.5 hours "on", 0.5 hour "off") at RCWV in a humidity test chamber controlled at $40^{\circ}\text{C} \pm 2^{\circ}\text{C}$ and 90 to 95 % relative humidity											
Resistance value	$\Delta R/R$																
Non-flame type	$\pm 5\%$																
Load life	<table border="1" style="width: 100%;"> <thead> <tr> <th style="text-align: center;">Resistance value</th> <th style="text-align: center;"><math>\Delta R/R</math></th> </tr> </thead> <tbody> <tr> <td style="text-align: center;">Non-flame type</td> <td style="text-align: center;"><math>\pm 5\%</math></td> </tr> </tbody> </table>	Resistance value	$\Delta R/R$	Non-flame type	$\pm 5\%$	7.10 Permanent resistance change after 1,000 hours operating at RCWV with duty cycle of (1.5 hours "on", 0.5 hour "off") at $70^{\circ}\text{C} \pm 2^{\circ}\text{C}$ ambient											
Resistance value	$\Delta R/R$																
Non-flame type	$\pm 5\%$																

## Metal Film Fixed Resistors

### 6. Dimension :

Unit :mm

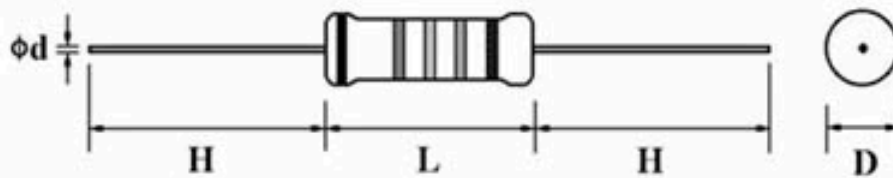

Type	Power Rating	D (Max.)	L (Max.)	d ± 0.05	H ± 3
MF	0.4W-SS	1.9 mm	3.7 mm	0.45 mm	28 mm

### Painting method:

Welding point, terminal and lead wire, is permissible to be exposed without the outer coated cover. The extent should be within 1/2 of the arc angle.

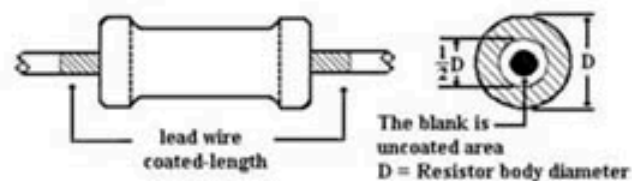

### 7. Marking :

#### 7.1 Resistor :

Resistors shall be marked with color coding  
colors shall be in accordance with JIS C 0802

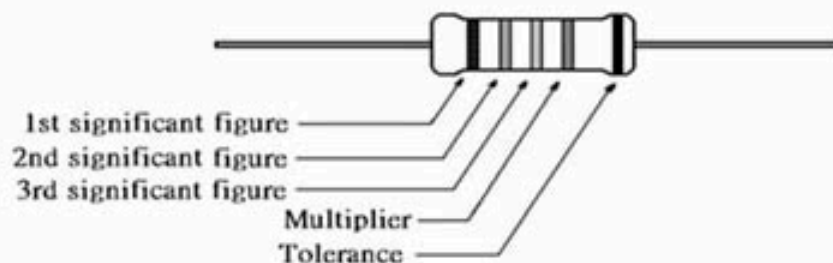

#### 7.2 Label :

Label shall be marked with following items:

- (1) Type and style
- (2) Nominal resistance
- (3) Resistance tolerance
- (4) Quantity
- (5) Lot number
- (6) PPM

Example :

Metal Film Fixed Resistors			
Watt :	0.4W-SS	Val :	22K
Q'TY :	5,000	Tol :	1%
Lot :	319022	PPM :	50
ROYALOHM		Pb Free	

## Metal Film Fixed Resistors

### 8. Packing specification :

#### 8.1 Taping dimension :

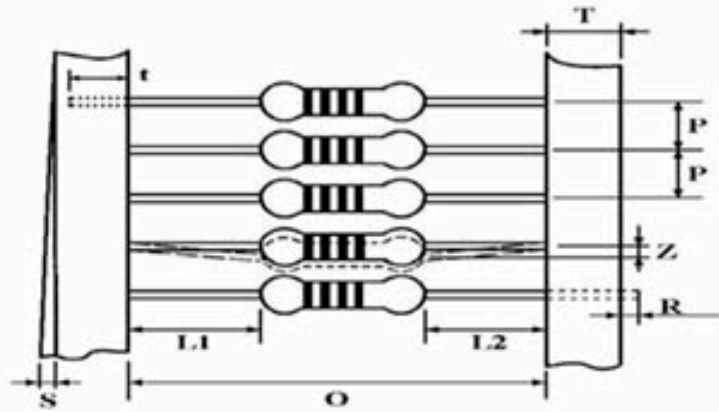

Dimensions (mm)

Type	Style	O	P	L1-L2	T	Z	R	t	S
MF-40ss	PT-52	52 ± 1	5 ± 0.3	1 Max.	6 ± 1	1 Max.	0	4 ± 1	0.5 Max.

#### 8.2 Tape in box packing :

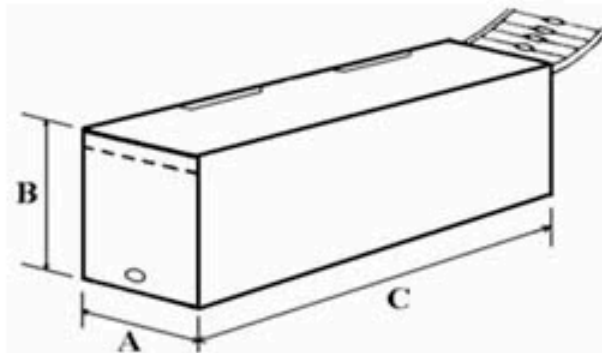

Bandoliers may also be contained in a cardboard box ("Ammopack")

Dimension (mm)

Type	Style	L (C) ± 5	W (A) ± 5	H (B) ± 5	Quantity Per Box (pcs.)
MF-40ss	PT-52	250	75	66	5,000

"Ammopack" is an abbreviation of "ammunition pack"



## Metal Film Fixed Resistors

### 8.3 Tape on reel packing :

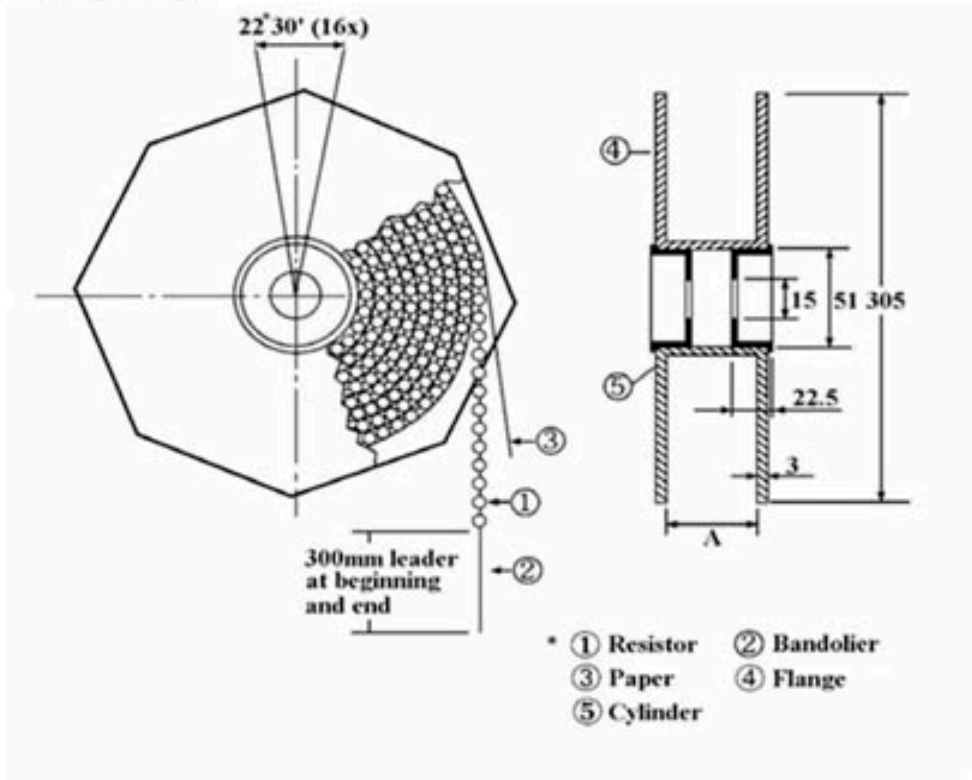

Dimension (mm) :

Type	Style	Across Flange (A)	Quantity Per Reel
MF-40ss	PT-52	$73 \pm 2$	5,000 pcs.

## Part Number System

### Explanation of Part Number System (Metal Film Fixed Resistors)

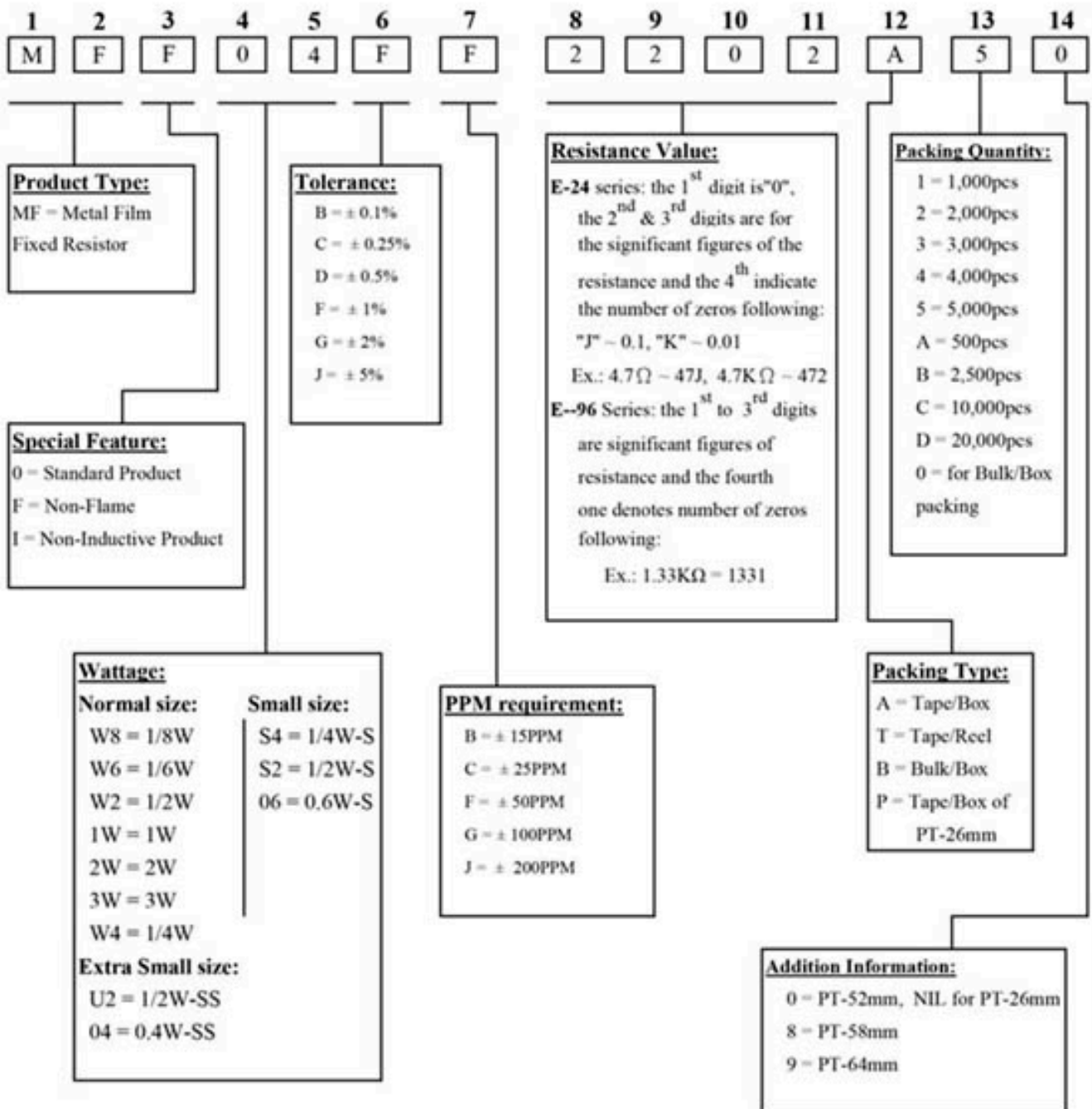

Sample: MF 0.4W-SS +/- 1% 50ppm 22KΩ T/B 5,000 → MFF04FF2202A50

# ROYALOHM

**C O N F I D E N T I A L   D O C U M E N T**

SPECIFICATION FOR APPROVAL

**TRELIK**

Description : Metal Film Fixed Resistors

( UL Non-Flame paint )

**Royalohm Part no.:**

MFF04FFxxxxA50 (MF 0.4W-SS +/- 1% 50ppm T/B-5,000)

Approved by

**Parts corresponding to RoHS Compliant: 2005-Apr.-1**

Royal Electronic Factory (Thailand) Co., Ltd.

20/1-2 Moo 2 Klong-Na, Muang

Chachoengsao 24000, Thailand

Tel: +66-38-822404-8

Fax: +66 38-981190 / 823765

E-mail Address: Export sales: [Export@royalohm.com](mailto:Export@royalohm.com)

Local sales: [Local@royalohm.com](mailto:Local@royalohm.com)

<http://www.royalohm.com>

P.O. Box 251 Klongchan, Bangkok 10240, Thailand

Approved	Checked	Prepared
Mr. Jack Lin	Mr. S. Polthanasan	Ms.P. Supatta

Issued Date: 2014/12/11



Customer: **TRELIK**

Part No.: **MFF04FFxxxxA50**

1. Scope:

This specification for approval relates to Metal Film Fixed Resistors manufactured by ROYALOHM 's specifications.

2. Type designation:

The type designation shall be in the following form :

(Ex.)	<u>MF</u>	<u>0.4W-SS</u>	<u>F</u>	<u>10MΩ</u>
	Type	Power Rating	Resistance Tolerance	Nominal Resistance

3. Ratings:

Ratings shall be shown in the table 1.

Table 1

Type	MF
Rated Power	0.4W-SS at 70 °C
Max. Working Voltage	200 V
Max. Overload Voltage	400 V
Dielectric Withstanding Voltage	200 V
Rated Ambient Temp.	70 °C
Operating Temp. Range	-55 °C --- +155 °C
Resistance Tolerance	± 1%
Resistance Range	1.1MΩ ~ 10MΩ

3.1 Power rating:

Resistors shall have a power rating based on continuous full load operation at an ambient temperature of 70 °C. For temperature in excess of 70 °C , the load shall be derated as shown in the figure 1.

3.2 Voltage rating:

Resistors shall have a rated direct-current (DC) continuous working voltage or an approximate sine-wave root-mean-square (RMS) alternating-current (AC) continuous working voltage at commercial-line frequency and waveform corresponding to the power rating , as determined from the following formula :

$$RCWV = \sqrt{P \times R}$$

Were : RCWV = Rated DC or RMS AC continuous working voltage at commercial-line frequency and waveform (volt)

P = Power Rating (watt)

R = Nominal Resistance (ohm)

### Metal Film Fixed Resistors

In no case shall the rated DC or RMS AC continuous working voltage be greater than the applicable maximum value

Figure 1.

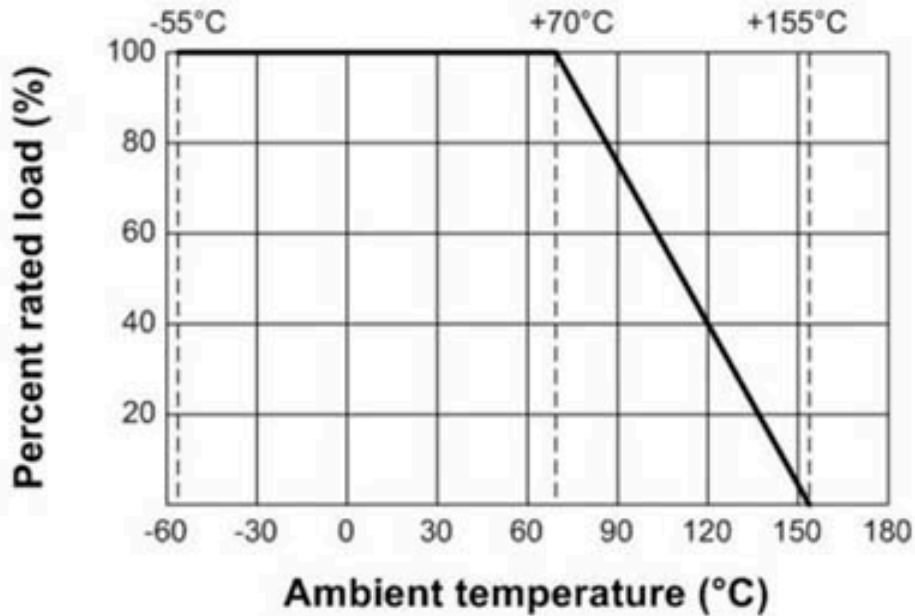

3.3 Nominal resistance :

Effective figures of nominal resistance shall be in accordance with E-96 series, and resistance tolerance shall be shown by table 1.

4. Construction :

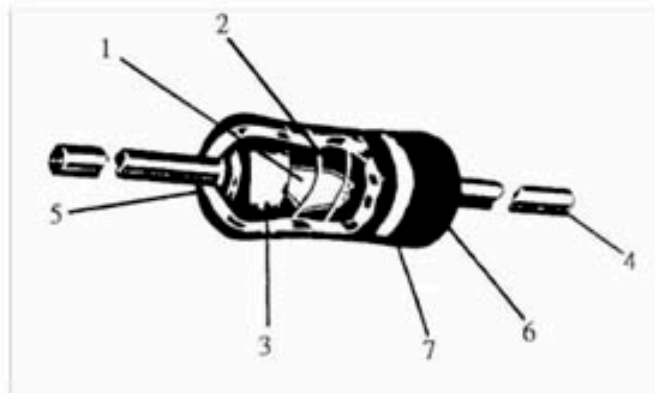

No.	Name	Material
1	Basic Body	Rod Type Ceramics
2	Resistance Film	Metal Film
3	End Cap	Steel (Tin plated iron surface)
4	Lead Wire	Annealed copper wire coated with tin
5	Joint	By Welding
6	Coating	Insulated & Non-Flame Paint ( Color : Green Meeting U L 94 V O Standard )
7	Color Code	Non-Flame Paint Epoxy Resin

### Metal Film Fixed Resistors

#### 5. Characteristics :

Characteristics	Limits	Test Methods ( JIS C 5201-1 )
DC. resistance	Must be within the specified tolerance	The limit of error of measuring apparatus shall not exceed allowable range or 1% of resistance tolerance (Sub-clause 4.5)
Insulation resistance	Min. 10,000 Mega Ohm	Resistors shall be clamped in the trough of a 90° metallic V-block or foil method use a metal foil shall be wrapped closely around the body of the resistor. After that shall be tested at DC potential respectively specified in the above list for 60 +10/-0 secs. (Sub-clause 4.6)
Dielectric withstanding voltage	No evidence of flashover mechanical damage, arcing or insulation break down	Resistors shall be clamped in the trough of a 90° metallic V-block or foil method use a metal foil shall be wrapped closely around the body of the resistor. After that shall be tested at AC potential respectively specified in the table 1. for 60 +10/-0 secs. (Sub-clause 4.7)
Temperature coefficient	± 50 PPM/°C	Natural resistance change per temp. degree centigrade $\frac{R_2 - R_1}{R_1(t_2 - t_1)} \times 10^6 \text{ (PPM/°C)}$ R1: Resistance value at room temperature (t1) R2: Resistance value at room temp. plus 100 °C (t2) (Sub-clause 4.8)
Short time overload	Resistance change rate is ± (0.5% + 0.05 Ω) Max. with no evidence of mechanical damage	Permanent resistance change after the application of a potential of 2.5 times RCWV for 5 seconds (Sub-clause 4.13)
Terminal strength	No evidence of mechanical damage	<b>Direct load :</b> Resistance to a 2.5 kgs direct load for 10 secs. in the direction of the longitudinal axis of the terminal leads <b>Twist test :</b> Terminal leads shall be bent through 90 ° at a point of about 6mm from the body of the resistor and shall be rotated through 360° about the original axis of the bent terminal in alternating direction for a total of 3 rotations (Sub-clause 4.16)
Solderability	95 % coverage Min.	The area covered with a new, smooth, clean, shiny and continuous surface free from concentrated pinholes. Test temp. of solder : 245°C ± 3°C Dwell time in solder : 2 ~ 3 seconds (Sub-clause 4.17)

Metal Film Fixed Resistors																	
Characteristics	Limits	Test Methods ( JIS C 5201-1 )															
Soldering temp. reference	Electrical characteristics shall be satisfied. Without distinct deformation in appearance. (95 % coverage Min.)	The leads immersed into solder bath to 3.2 to 4.8 mm. from the body. Permanent resistance change shall be checked. Wave soldering condition: (2 cycles Max.) Pre-heat : 100 ~ 120 °C, 30 ± 5 sec. Suggestion solder temp.: 235 ~ 255 °C, 10 sec. (Max.) Peak temp.: 260 °C Hand soldering condition: Hand Soldering bit temp. : 380 ± 10 °C Dwell time in solder : 3 +1/-0 sec.															
Resistance to soldering heat	Resistance change rate is ± (1% + 0.05 Ω) Max. with no evidence of mechanical damage	Permanent resistance change when leads immersed to 3.2 to 4.8 mm from the body in 350°C ± 10 °C solder for 3 ± 0.5 seconds (Sub-clause 4.18)															
Temperature cycling	Resistance change rate is ± (1% + 0.05 Ω) Max. with no evidence of mechanical damage	Resistance change after continuous 5 cycles for duty shown below:															
		<table border="1"> <thead> <tr> <th>Step</th> <th>Temperature</th> <th>Time</th> </tr> </thead> <tbody> <tr> <td>1</td> <td>-55°C ± 3°C</td> <td>30 mins</td> </tr> <tr> <td>2</td> <td>Room temp.</td> <td>10~15 mins</td> </tr> <tr> <td>3</td> <td>+155°C ± 2°C</td> <td>30 mins</td> </tr> <tr> <td>4</td> <td>Room temp.</td> <td>10~15 mins</td> </tr> </tbody> </table>	Step	Temperature	Time	1	-55°C ± 3°C	30 mins	2	Room temp.	10~15 mins	3	+155°C ± 2°C	30 mins	4	Room temp.	10~15 mins
		Step	Temperature	Time													
		1	-55°C ± 3°C	30 mins													
		2	Room temp.	10~15 mins													
3	+155°C ± 2°C	30 mins															
4	Room temp.	10~15 mins															
(Sub-clause 4.19)																	
Vibration	Resistance change rate is ± (1% + 0.05 Ω) Max.	55Hz, 3 planes 2hrs each Total amplitude = 1.5mm (Sub-clause 4.22)															
Load life in humidity	Resistance value	Δ R/R															
	Non-flame type	± 5 %															
		Resistance change after 1,000 hours (1.5 hours "on", 0.5 hour "off") at RCWV in a humidity test chamber controlled at 40 °C ± 2 °C and 90 to 95 % relative humidity (Sub-clause 4.24.2.1)															
Load life	Resistance value	Δ R/R															
	Non-flame type	± 5 %															
		Permanent resistance change after 1,000 hours operating at RCWV with duty cycle of (1.5 hours "on", 0.5 hour "off") at 70°C ± 2°C ambient (Sub-clause 4.25.1)															
Resistance to solvent	No deterioration of protective coatings and markings	Specimens shall be immersed in bath of trichroethane completely for 3 mins. with ultrasonic (Sub-clause 4.30)															
Pulse overload	Resistance change rate is ± (1% + 0.05 Ω) Max. with no evidence of mechanical damage	Resistance change after 10,000 cycles (1 sec. "on" , 25 secs. "off" ) at 4 times RCWV (Sub-clause 5.8)															



Metal Film Fixed Resistors																	
Characteristics	Limits	Test Methods ( JIS C 5201-1 )															
Soldering temp. reference	Electrical characteristics shall be satisfied. Without distinct deformation in appearance. (95 % coverage Min.)	The leads immersed into solder bath to 3.2 to 4.8 mm. from the body. Permanent resistance change shall be checked. Wave soldering condition: (2 cycles Max.) Pre-heat : 100 ~ 120 °C, 30 ± 5 sec. Suggestion solder temp.: 235 ~ 255 °C, 10 sec. (Max.) Peak temp.: 260 °C Hand soldering condition: Hand Soldering bit temp. : 380 ± 10 °C Dwell time in solder : 3 +1/-0 sec.															
Resistance to soldering heat	Resistance change rate is ± (1% + 0.05 Ω) Max. with no evidence of mechanical damage	Permanent resistance change when leads immersed to 3.2 to 4.8 mm from the body in 350°C ± 10 °C solder for 3 ± 0.5 seconds (Sub-clause 4.18)															
Temperature cycling	Resistance change rate is ± (1% + 0.05 Ω) Max. with no evidence of mechanical damage	Resistance change after continuous 5 cycles for duty shown below:															
		<table border="1"> <thead> <tr> <th>Step</th> <th>Temperature</th> <th>Time</th> </tr> </thead> <tbody> <tr> <td>1</td> <td>-55°C ± 3°C</td> <td>30 mins</td> </tr> <tr> <td>2</td> <td>Room temp.</td> <td>10~15 mins</td> </tr> <tr> <td>3</td> <td>+155°C ± 2°C</td> <td>30 mins</td> </tr> <tr> <td>4</td> <td>Room temp.</td> <td>10~15 mins</td> </tr> </tbody> </table>	Step	Temperature	Time	1	-55°C ± 3°C	30 mins	2	Room temp.	10~15 mins	3	+155°C ± 2°C	30 mins	4	Room temp.	10~15 mins
		Step	Temperature	Time													
		1	-55°C ± 3°C	30 mins													
		2	Room temp.	10~15 mins													
3	+155°C ± 2°C	30 mins															
4	Room temp.	10~15 mins															
(Sub-clause 4.19)																	
Vibration	Resistance change rate is ± (1% + 0.05 Ω) Max.	55Hz, 3 planes 2hrs each Total amplitude = 1.5mm (Sub-clause 4.22)															
Load life in humidity	Resistance value	Δ R/R															
	Non-flame type	± 5 %															
		Resistance change after 1,000 hours (1.5 hours "on", 0.5 hour "off") at RCWV in a humidity test chamber controlled at 40 °C ± 2 °C and 90 to 95 % relative humidity (Sub-clause 4.24.2.1)															
Load life	Resistance value	Δ R/R															
	Non-flame type	± 5 %															
		Permanent resistance change after 1,000 hours operating at RCWV with duty cycle of (1.5 hours "on", 0.5 hour "off") at 70°C ± 2°C ambient (Sub-clause 4.25.1)															
Resistance to solvent	No deterioration of protective coatings and markings	Specimens shall be immersed in bath of trichroethane completely for 3 mins. with ultrasonic (Sub-clause 4.30)															
Pulse overload	Resistance change rate is ± (1% + 0.05 Ω) Max. with no evidence of mechanical damage	Resistance change after 10,000 cycles (1 sec. "on" , 25 secs. "off" ) at 4 times RCWV (Sub-clause 5.8)															

### Metal Film Fixed Resistors

6. Dimension :

Unit :mm

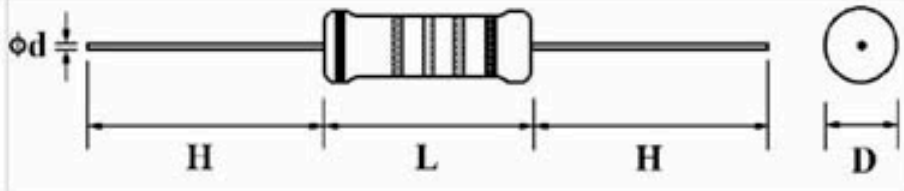

Type	Power Rating	D (Max.)	L (Max.)	d ± 0.05	H ± 3
MF	0.4W-SS	1.9 mm	3.7 mm	0.45 mm	28 mm

Painting method:

Welding point, terminal and lead wire, is permissible to be exposed without the outer coated cover. The extent should be within 1/2 of the arc angle.

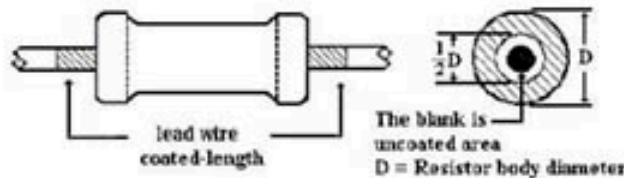

7. Marking :

7.1 Resistor :

Resistors shall be marked with color coding colors shall be in accordance with JIS C 0802

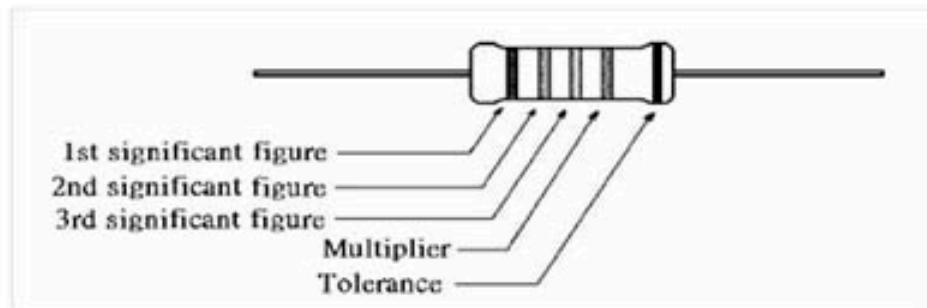

7.2 Label :

Label shall be marked with following items:

- (1) Type and style
- (2) Nominal resistance
- (3) Resistance tolerance
- (4) Quantity
- (5) Lot number
- (6) PPM

Example :

Metal Film Fixed Resistors			
Watt :	0.4W-SS	Val :	10M
Q'TY :	5,000	Tol :	1%
Lot :	319022	PPM :	50
ROYALOHM		Pb Free	

### Metal Film Fixed Resistors

8. Packing specification :

8.1 Taping dimension :

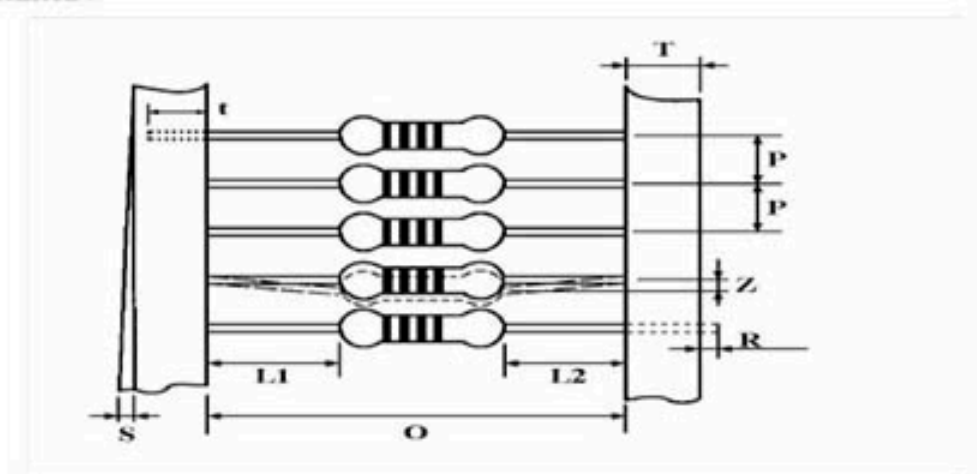

Dimensions (mm)

Type	Style	O	P	L1-L2	T	Z	R	t	S
MF-40-SS	PT-52	52 ± 1	5 ± 0.3	1 Max.	6 ± 1	1 Max.	0	4 ± 1	0.5 Max.

8.2 Tape in box packing :

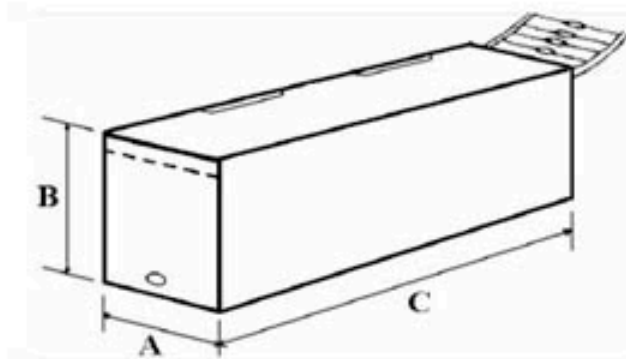

Bandoliers may also be contained in a cardboard box ("Ammopack")

Dimension (mm)

Type	Style	L (C) ± 5	W (A) ± 5	H (B) ± 5	Quantity Per Box (pcs.)
MF-40-SS	PT-52	250	75	66	5,000

"Ammopack" is an abbreviation of "ammunition pack"

### Metal Film Fixed Resistors

8.3 Tape on reel packing :

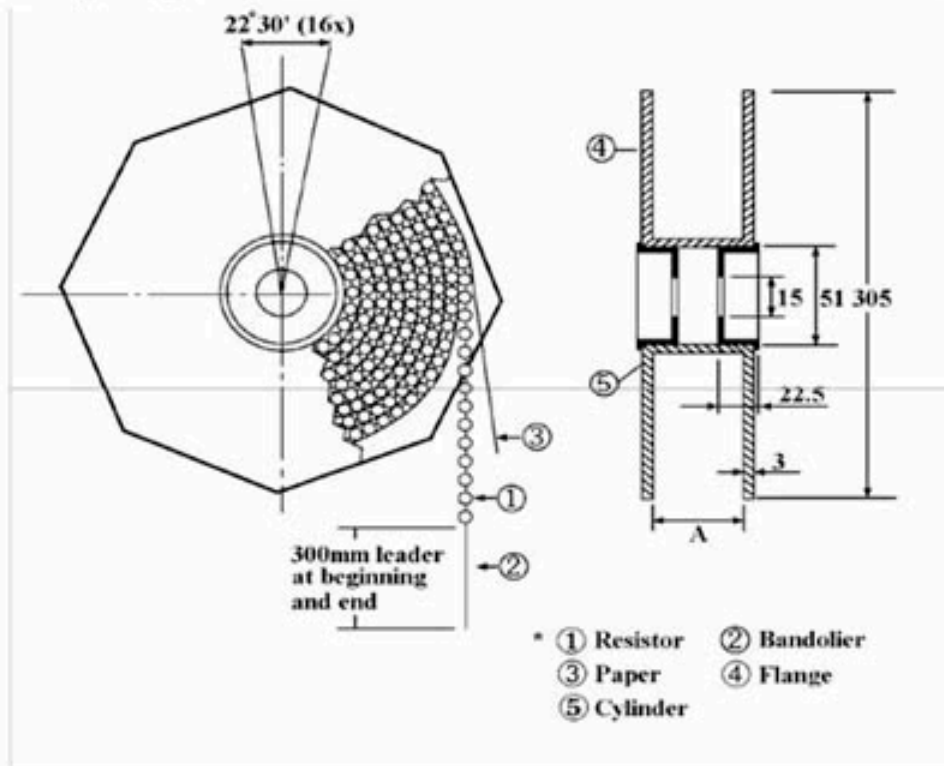

Dimension (mm) :

Type	Style	Across Flange (A)	Quantity Per Reel
MF-40-SS	PT-52	73 ± 2	5,000 pcs.

**Part Number System**

**Explanation of Part Number System  
(Metal Film Fixed Resistors)**

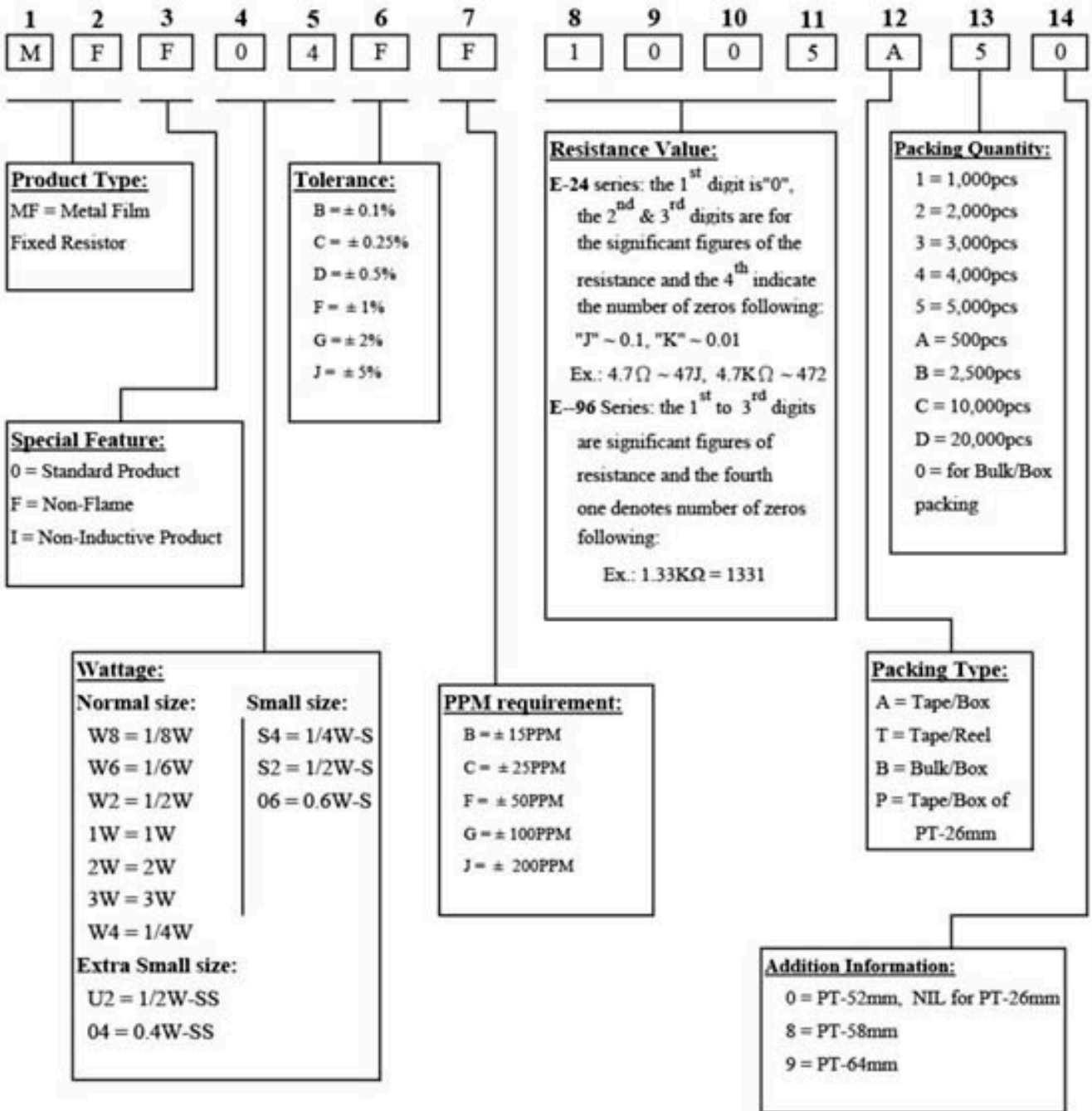

Sample: MF 0.4W-SS (UL Non-Flame paint) +/- 1% 50ppm 10MΩ T/B 5,000 → MFF04FF1005A50

## Metal Film Fixed Resistors

### Environment Related Substance

This product complies to EU RoHS directive, EU PAHs directive, EU PFOS directive and Halogen free.

Ozone layer depleting substances.

Ozone depleting substances are not used in our manufacturing process of this product.

This product is not manufactured using Chloro fluorocarbons (CFCs), Hydrochlorofluorocarbons (HCFCs), Hydrobromofluorocarbons (HBFCs) or other ozone depleting substances in any phase of the manufacturing process.

### Storage Condition

The performance of these products, including the solderability, is guaranteed for a year from the date of arrival at your company, provided that they remain packed as they were when delivered and stored at a temperature of  $25^{\circ}\text{C} \pm 5^{\circ}\text{C}$  and a relative humidity of  $60\%\text{RH} \pm 10\%\text{RH}$

Even within the above guarantee periods, do not store these products in the following conditions. Otherwise, their electrical performance and/or solderability may be deteriorated, and the packaging materials (e.g. taping materials) may be deformed or deteriorated, resulting in mounting failures.

1. In salty air or in air with a high concentration of corrosive gas, such as  $\text{Cl}_2$ ,  $\text{H}_2\text{S}$ ,  $\text{NH}_3$ ,  $\text{SO}_2$ , or  $\text{NO}_2$
2. In direct sunlight