

ROYALOHM

SPECIFICATION FOR APPROVAL

TRELIK COMERCIAL IMPORTADORA LTD.

Description : Thick Film Chip Resistors (Terminal Lead Free)

Royalohm Part no.:

0603WAxxxxT5E (RMC 1/10W (0603)+/-1%, 5% & Jumper T/R-5K)

Approved by

Parts corresponding to RoHS Compliant: 2005-Apr.-1

Royal Electronic Factory (Thailand) Co., Ltd.

20/1-2 Moo 2 Klong-Na, Muang

Chachoengsao 24000, Thailand

Tel: +66-38-822404-8

Fax: +66 38-981190 / 823765

E-mail Address: Export sales: Export@royalohm.com

Local sales: Local@royalohm.com

<http://www.royalohm.com>

P.O. Box 251 Klongchan, Bangkok 10240, Thailand

Approved	Checked	Prepared
Mr. Jack Lin	Mr. S. Polthanasan	Ms. T. Suparuch

Issue Date: 2009/08/17

1. Scope:

This specification for approval relates to Thick Film Chip Resistors (Terminal Lead Free) manufactured by ROYALOHM 's specifications.

2. Type designation:

The type designation shall be in the following form:

Type	Power Rating	Resistance tolerance	Nominal Resistance
<u>Ex.</u> RMC 0603	0.10W (1/10W)	F, J	10K Ω

3. Ratings:

Type	RMC 0603
Power Rating	0.10W (1/10W)
Rated Current (Jumper)	1A
Max. Overload Current (Jumper)	2A
Max. Working Voltage	50V
Max. Overload Voltage	100V
Temperature Range	-55 $^{\circ}$ C ~ +155 $^{\circ}$ C
Ambient Temperature	70 $^{\circ}$ C

3.1 Power rating:

Resistors shall have a power rating based on continuous load operation at an ambient temperature of 70 $^{\circ}$ C . For temperature in excess of 70 $^{\circ}$ C , The load shall be derate as shown in figure 1.

Figure 1

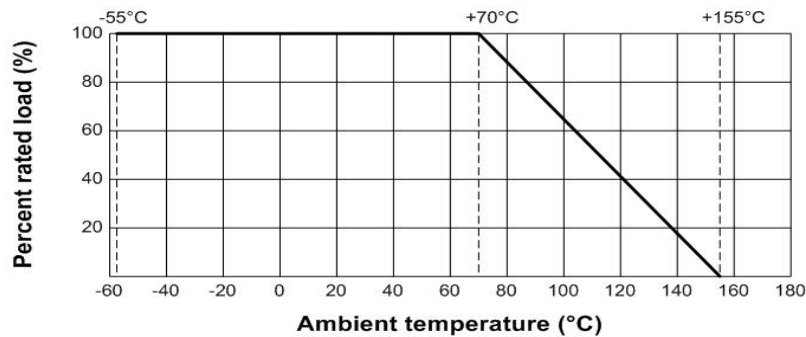

3.2 Nominal Resistance

Effective figures of nominal resistance shall be in accordance with E-24 and E-96 series. E-96 series for 1% and E-24 series for 2%, 5%.

Thick Film Chip Resistors (Terminal Lead Free)

4. Construction :

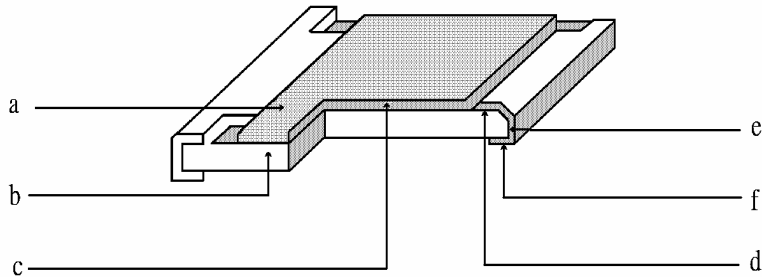

- | | |
|---|--|
| a. Protective coating : Epoxy | d. Termination (Inner) : Ag/Pd |
| b. Al ₂ O ₃ high purity alumina substrate : Al 96 % | e. Termination (Between) : Ni plating film |
| c. Resistive element : RuO ₂ , Ag, Glass | f. Termination (Outer) : Sn plating film |

5. Power rating and dimensions

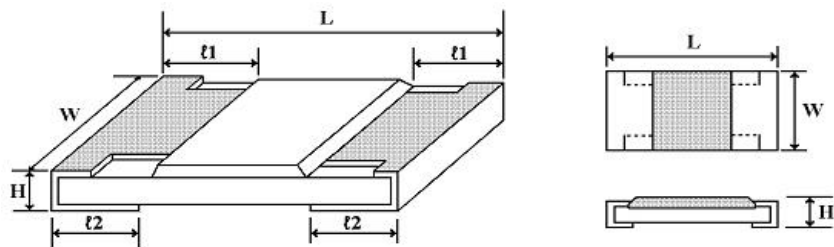

Dimension :

Type	Dimension (mm)				
	$L \pm 0.10$	$W + 0.15$ $- 0.10$	$H \pm 0.10$	$t1 \pm 0.20$	$t2 \pm 0.20$
RMC 0603	1.60	0.80	0.45	0.30	0.30

Power Rating :

Type	Power Rating at 70 °C	Tolerance %	Resistance Range	Standard Series
RMC 0603	0.10W (1/10W)	Jumper ± 1 ± 5	< 50mΩ 1Ω ~ 1MΩ 1Ω ~ 10MΩ	E-96 E-24

Thick Film Chip Resistors (Terminal Lead Free)

6. Marking :

6.1 Resistors

A. Marking for E-96 series in 0603 size: 3 Digits (due to space restrictions)

*Using the Multiplier code, please refer to coding formula

Multiplier Code :

Code	A	B	C	D	E	F	G	H	X	Y	Z
Multiplier	10 ⁰	10 ¹	10 ²	10 ³	10 ⁴	10 ⁵	10 ⁶	10 ⁷	10 ⁻¹	10 ⁻²	10 ⁻³

Value	Code	Value	Code	Value	Code	Value	Code	Value	Code
100	01	162	21	261	41	422	61	681	81
102	02	165	22	267	42	432	62	698	82
105	03	169	23	274	43	442	63	715	83
107	04	174	24	280	44	453	64	732	84
110	05	178	25	287	45	464	65	750	85
113	06	182	26	294	46	475	66	768	86
115	07	187	27	301	47	487	67	787	87
118	08	191	28	309	48	499	68	806	88
121	09	196	29	316	49	511	69	825	89
124	10	200	30	324	50	523	70	845	90
127	11	205	31	332	51	536	71	866	91
130	12	210	32	340	52	549	72	887	92
133	13	215	33	348	53	562	73	909	93
137	14	221	34	357	54	576	74	931	94
140	15	226	35	365	55	590	75	953	95
143	16	232	36	374	56	604	76	976	96
147	17	237	37	383	57	619	77		
150	18	243	38	392	58	634	78		
154	19	249	39	402	59	649	79		
158	20	255	40	412	60	665	80		

Ex.

	01X	
--	-----	--

$$10\Omega = 100 \times 10^{-1} = 01X$$

*The resistance value that no have multiplier code indicate marking follow this:

The first 2 digits are significant figures of resistance and the 3rd digit denoted number of zeros. and under line the marking letters.

Ex.

	<u>1R2</u>	
--	------------	--

$$1.2\Omega$$

B. Marking for E-24 series in 0603 size : 3 Digits

*The first 2 digits are significant figures of resistance and the 3rd digit denoted number of zeros.

Ex.

	273	
--	-----	--

$$27K\Omega$$

*For ohmic values below 10 Ω , letter "R" is for decimal point.

Ex.

	R68	
--	-----	--

$$0.68\Omega$$

6.2 Labels

Label shall be marked with the following item :

- A. Nominal Resistance and Resistance Tolerance
- B. Power Rating and Size
- C. Quantity
- D. Part No.
- E. P.O.No.
- F. Lot No.

ROYALOHM CHIP RESISTOR		
RESISTANCE:	10 Ω	$\pm 1\%$
WATTAGE:	1/10W	SIZE: 0603
QUANTITY:	5,000 PCS	Pb-Free
PART NO.:		
P.O.NO.:		
LOT NO. :	825723	0603WAF100JT5E
		

Remark:

$\pm 1\%$: Label is 10E, value is 10 Ω , marking is 01X

Thick Film Chip Resistors (Terminal Lead Free)

7. Performance specification :

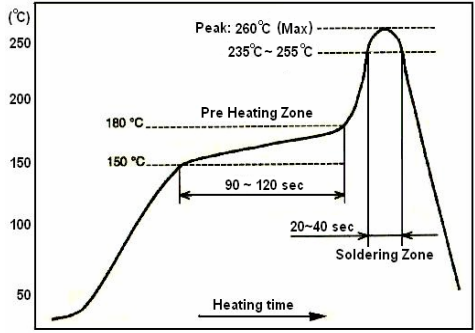
Characteristics	Limits	Test Methods (JIS C 5201-1)
*Insulation resistance	1,000 MΩ or more	Apply 500V DC between protective coating and termination for 1 min, then measure (Sub-clause 4.6)
*Dielectric withstanding voltage	No evidence of flashover mechanical damage, arcing or insulation break down	Apply 500V AC between protective coating and termination for 1 minute (Sub-clause 4.7)
Temperature coefficient	1Ω-10Ω : ± 400 PPM/°C 11Ω-100Ω : ± 200 PPM/°C >100Ω : ± 100 PPM/°C	Natural resistance change per temp. degree centigrade. $\frac{R_2 - R_1}{R_1(t_2 - t_1)} \times 10^6 \quad (\text{PPM}/^\circ\text{C})$ R1: Resistance value at room temperature (t1) R2: Resistance value at room temp. plus 100 °C (t2) (Sub-clause 4.8)
Short time overload	Resistance change rate is ± 5% (2.0% + 0.1 Ω) Max. ± 1% (1.0% + 0.1 Ω) Max.	Permanent resistance change after the application of a potential of 2.5 times RCWV for 5 seconds (Sub-clause 4.13)
*Solderability	95 % coverage Min.	Test temperature of solder : 245 ± 3°C Dipping them solder : 2-3 seconds (Sub-clause 4.17)
Soldering temp. reference	Electrical characteristics shall be satisfied. Without distinct deformation in appearance. (95 % coverage Min.)	<p><u>Wave soldering condition:</u> (2 cycles Max.) Pre-heat : 100 ~ 120 °C, 30 ± 5 sec. Suggestion solder temp.: 235 ~ 255 °C, 10 sec. (Max.) Peak temp.: 260 °C</p> <p><u>Reflow soldering condition:</u> (2 cycles Max.) Pre-heat : 150 ~ 180 °C, 90 ~ 120 sec. Suggestion solder temp.: 235 ~ 255 °C, 20 ~ 40 sec. Peak temp.: 260 °C</p>  <p style="text-align: center;">Temperature profile for avaluation</p> <p><u>Hand soldering condition:</u> The soldering iron tip temperature should be less than 300°C and maximum contract time should be 5 sec.</p>

Thick Film Chip Resistors (Terminal Lead Free)

7. Performance specification :

Characteristics	Limits	Test Methods (JIS C 5201-1)															
Soldering Heat	Resistance change rate is: $\pm(1\%+0.05\Omega)$ Max.	Dip the resistor into a solder bath having a temperature of $260^{\circ}\text{C}\pm 3^{\circ}\text{C}$ and hold it for 10 ± 1 seconds. (Sub-clause 4.18)															
Temperature cycling	Resistance change rate is $\pm 5\%$ ($1.0\% + 0.05 \Omega$) Max. $\pm 1\%$ ($0.5\% + 0.05 \Omega$) Max.	Resistance change after continuous 5 cycles for duty cycle specified below :															
		<table border="1" style="width: 100%; border-collapse: collapse;"> <thead> <tr> <th style="text-align: center;">Step</th> <th style="text-align: center;">Temperature</th> <th style="text-align: center;">Time</th> </tr> </thead> <tbody> <tr> <td style="text-align: center;">1</td> <td style="text-align: center;">$-55^{\circ}\text{C} \pm 3^{\circ}\text{C}$</td> <td style="text-align: center;">30 mins</td> </tr> <tr> <td style="text-align: center;">2</td> <td style="text-align: center;">Room temp.</td> <td style="text-align: center;">10~15 mins</td> </tr> <tr> <td style="text-align: center;">3</td> <td style="text-align: center;">$+155^{\circ}\text{C} \pm 2^{\circ}\text{C}$</td> <td style="text-align: center;">30 mins</td> </tr> <tr> <td style="text-align: center;">4</td> <td style="text-align: center;">Room temp.</td> <td style="text-align: center;">10~15 mins</td> </tr> </tbody> </table>	Step	Temperature	Time	1	$-55^{\circ}\text{C} \pm 3^{\circ}\text{C}$	30 mins	2	Room temp.	10~15 mins	3	$+155^{\circ}\text{C} \pm 2^{\circ}\text{C}$	30 mins	4	Room temp.	10~15 mins
		Step	Temperature	Time													
		1	$-55^{\circ}\text{C} \pm 3^{\circ}\text{C}$	30 mins													
		2	Room temp.	10~15 mins													
3	$+155^{\circ}\text{C} \pm 2^{\circ}\text{C}$	30 mins															
4	Room temp.	10~15 mins															
(Sub-clause 4.19)																	
Load life in humidity	Resistance change rate is $\pm 5\%$ ($3.0\% + 0.1 \Omega$) Max. $\pm 1\%$ ($1.0\% + 0.1 \Omega$) Max.	Resistance change after 1,000 hours (1.5 hours "on", 0.5 hour "off") at RCWV in a humidity chamber controlled at $40^{\circ}\text{C} \pm 2^{\circ}\text{C}$ and 90 to 95 % relative humidity (Sub-clause 4.24.2.1)															
Load Life	Resistance change rate is $\pm 5\%$ ($3.0\% + 0.1 \Omega$) Max. $\pm 1\%$ ($1.0\% + 0.1 \Omega$) Max.	Permanent resistance change after 1,000 hours operating at RCWV, with duty cycle of (1.5 hours"on", 0.5 hour"off") at $70^{\circ}\text{C} \pm 2^{\circ}\text{C}$ ambient (Sub-clause 4.25.1)															
Terminal bending	Resistance change rate is $\pm (1.0\% + 0.05 \Omega)$ Max.	Twist of Test Board : Y/X = 5/90 mm for 10 seconds (Sub-clause 4.33)															

The resistors of 0Ω only can do the characteristic noted of *

Thick Film Chip Resistors (Terminal Lead Free)

8. Packing specification :

* Taping Dimension (mm)

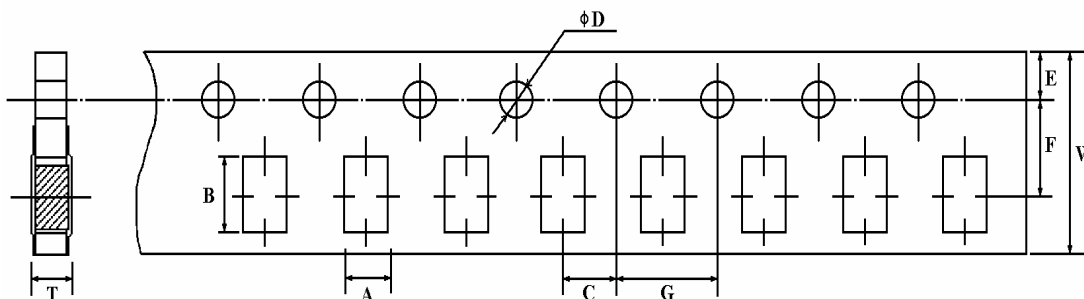

Type	$A \pm 0.2$	$B \pm 0.2$	$C \pm 0.05$	$\phi D \begin{matrix} +0.1 \\ -0 \end{matrix}$	$E \pm 0.1$	$F \pm 0.05$	$G \pm 0.1$	$W \pm 0.2$	$T \pm 0.1$
RMC 0603	1.10	1.90	2.0	1.5	1.75	3.5	4.0	8.0	0.67

* Reel Dimension (mm)

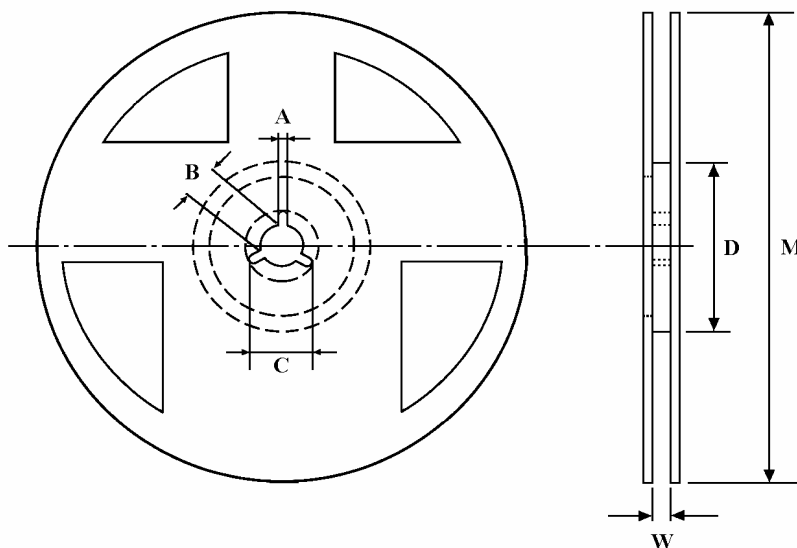

Type	Quantity Per Reel	$A \pm 0.5$	$B \pm 0.5$	$C \pm 0.5$	$D \pm 1$	$M \pm 2$	$W \pm 1$
RMC 0603	5,000 pcs. / Reel	2	13	21	60	178	10

Remark : ϕM 10,000pcs. / Reel = $255 \pm 2\text{mm}$
 20,000pcs. / Reel = $330 \pm 2\text{mm}$

Part Number System

Explanation of Part Number System Thick Film Chip Resistors (Terminal Lead Free)

1	2	3	4	5	6	7	8	9	10	11	12	13	14
0	6	0	3	W	A	J	0	1	0	3	T	5	E

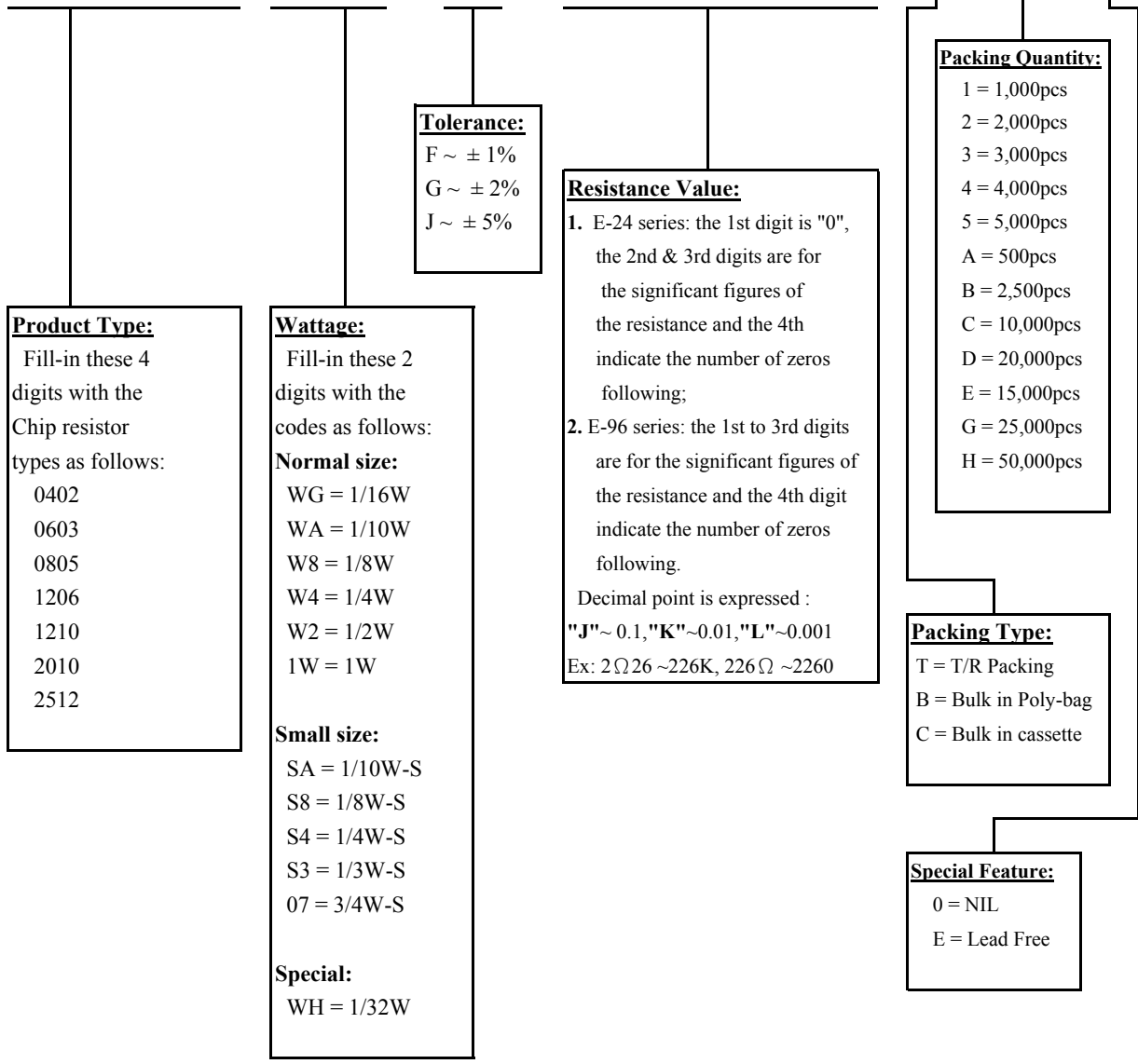

Sample : RMC 1/10W (0603) +/- 5% 10KΩ T/R--5000 → 0603WAJ0103T5E
RMC 1/10W (0603) +/- 5% 0Ω T/R--5000 → 0603WAJ0000T5E
RMC 1/10W (0603) +/- 1% 10KΩ T/R--5000 → 0603WAF1002T5E

Thick Film Chip Resistors (Terminal Lead Free)

Environment Related Substance

This product complies to EU RoHS directive, EU PAHs directive, EU PFOS directive and Halogen free.

Ozone layer depleting substances.

Ozone depleting substances are not used in our manufacturing process of this product.

This product is not manufactured using Chloro fluorocarbons (CFCs), Hydrochlorofluorocarbons (HCFCs), Hydrobromofluorocarbons (HBFCs) or other ozone depleting substances in any phase of the manufacturing process.

Storage Condition

The performance of these products, including the solderability, is guaranteed for a year from the date of arrival at your company, provided that they remain packed as they were when delivered and stored at a temperature of $25^{\circ}\text{C} \pm 5^{\circ}\text{C}$ and a relative humidity of $60\%\text{RH} \pm 10\%\text{RH}$

Even within the above guarantee periods, do not store these products in the following conditions. Otherwise, their electrical performance and/or solderability may be deteriorated, and the packaging materials (e.g. taping materials) may be deformed or deteriorated, resulting in mounting failures.

1. In salty air or in air with a high concentration of corrosive gas, such as Cl_2 , H_2S , NH_3 , SO_2 , or NO_2
2. In direct sunlight