

# ROYALOHM

**C O N F I D E N T I A L   D O C U M E N T**

SPECIFICATION FOR APPROVAL

**TRELIK COMERCIAL IMPORTADORA LTD.**

Description : Thick Film Chip Resistors (Terminal Lead Free)

**Royalohm Part no.:**

0201WMJxxxxTCE (RMC 1/20W (0201) +/-5% & Jumper)

Approved by

**Parts corresponding to RoHS Compliant: 2005-Apr.-1**

Royal Electronic Factory (Thailand) Co., Ltd.

20/1-2 Moo 2 Klong-Na, Muang

Chachoengsao 24000, Thailand

Tel: +66-38-822404-8

Fax: +66 38-981190 / 823765

E-mail Address: Export sales: [Export@royalohm.com](mailto:Export@royalohm.com)

Local sales: [Local@royalohm.com](mailto:Local@royalohm.com)

<http://www.royalohm.com>

P.O. Box 251 Klongchan, Bangkok 10240, Thailand

Approved	Checked	Prepared
Mr. Jack Lin	Mr. S. Polthanasan	Ms. N. Sureeporn

Issued Date: 2011/10/20



**Customer: TRELIK COMERCIAL IMPORTADORA LTD.**

**Part. No.: 0201WMJxxxxTCE**

1. Scope:

This specification for approval relates to Thick Film Chip Resistors (Terminal Lead Free) manufactured by ROYALOHM 's specifications.

2. Type designation:

The type designation shall be in the following form:

Type	Power Rating	Resistance tolerance	Nominal Resistance
<u>Ex.</u> RMC 0201	0.05W (1/20W)	J	220KΩ

3. Ratings:

Type	RMC 0201
Power Rating	0.05W (1/20W)
Rated Current (Jumper)	0.5A
Max. Overload Current (Jumper)	1A
Max. Working Voltage	25 V
Max. Overload Voltage	50 V
Temperature Range	-55°C ~ +155°C
Ambient Temperature	70 °C

3.1 Power rating:

Resistors shall have a power rating based on continuous load operation at an ambient temperature of 70 °C . For temperature in excess of 70 °C , The load shall be derate as shown in figure 1.

Figure 1

### Derating Curve

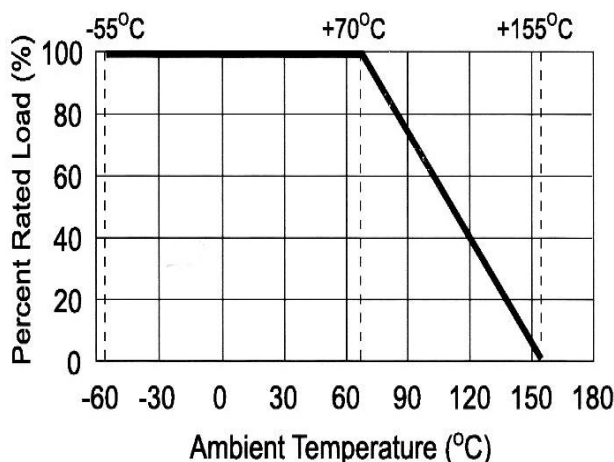

3.2 Nominal Resistance

Effective figures of nominal resistance shall be in accordance with E-24 and E-96 series E-96 series for 1 % and E-24 series for 2 % and 5 %

### Thick Film Chip Resistors (Terminal Lead Free)

4. Construction :

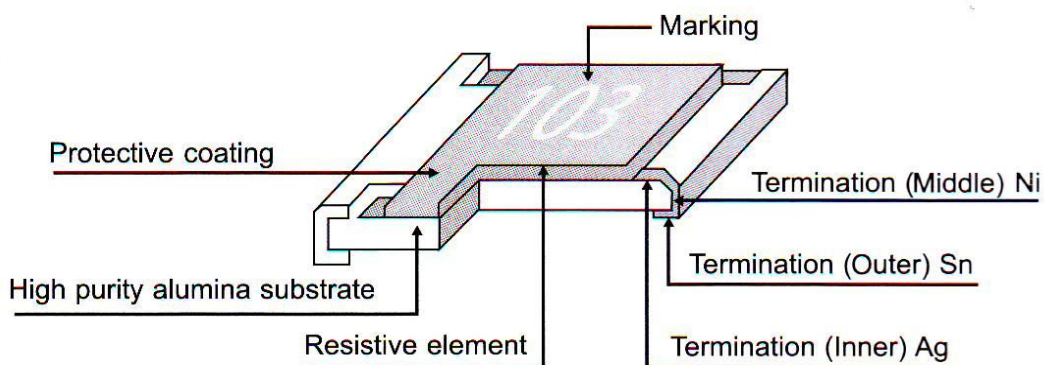

5. Power rating and dimensions

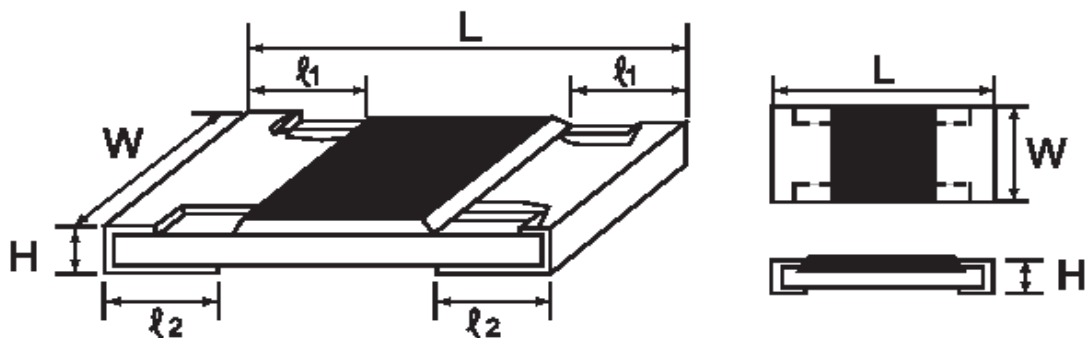

Dimension :

Type	Dimension (mm)				
	$L \pm 0.03$	$W \pm 0.03$	$H \pm 0.03$	$\ell_1 \pm 0.05$	$\ell_2 \pm 0.05$
RMC 0201	0.60	0.30	0.23	0.10	0.15

Power Rating :

Type	Power Rating at 70 °C	Tolerance %	Resistance Range	Standard Series
RMC 0201	0.05W (1/20W)	Jumper $\pm 5$	< 50mΩ 1Ω---1MΩ	E-24

### Thick Film Chip Resistors (Terminal Lead Free)

6. Marking :

6.1 Resistors

A. Chip Resistors type 0201 No marking

6.2 Labels

Label shall be marked with the following item :

A. Nominal Resistance and Resistance Tolerance

B. Power Rating and Size

C. Quantity

D. Part No.

E. P.O.No.

F. Lot No.

Ex.

<b>ROYALOHM</b>	
<b>CHIP RESISTOR</b>	
RESISTANCE:	220K $\Omega$ $\pm$ 5%
WATTAGE:	1/20W SIZE: 0201
QUANTITY:	10,000 PCS Pb-Free
PART NO.:	
P.O.NO.:	
LOT NO. :	6050008 0201WMF0224TCE
	

**Thick Film Chip Resistors (Terminal Lead Free)**

7. Performance specification :

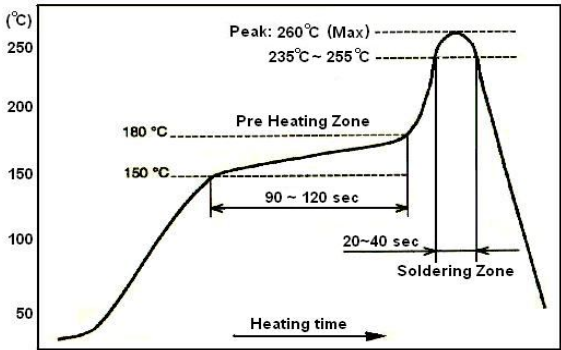
Characteristics	Limits	Test Methods ( JIS C 5201-1 )
Insulation resistance	1,000 MΩ or more	Apply 500V DC between protective coating and termination for 1 min, then measure (Sub-clause 4.6)
Dielectric withstanding voltage	No evidence of flashover mechanical damage, arcing or insulation break down	Apply 500V AC between protective coating and termination for 1 minute (Sub-clause 4.7)
Temperature coefficient	1Ω ~ 10Ω : ± 400 PPM/°C >10Ω : ± 200 PPM/°C	Natural resistance change per temp. degree centigrade. $\frac{R_2 - R_1}{R_1(t_2 - t_1)} \times 10^6 \text{ (PPM/°C)}$ R1: Resistance value at room temperature (t1) R2: Resistance value at room temp. plus 100 °C (t2) (Sub-clause 4.8)
Short time overload	Resistance change rate is ± (2.0% + 0.1Ω) Max.	Permanent resistance change after the application of a potential of 2.5 times RCWV for 5 seconds (Sub-clause 4.13)
Solderability	95 % coverage Min.	Test temperature of solder : 245 ± 3 °C Dwell time in solder : 2 ~ 3 seconds (Sub-clause 4.17)
Soldering temp. reference	Electrical characteristics shall be satisfied. Without distinct deformation in appearance. (95 % coverage Min.)	<p><u>Wave soldering condition:</u> (2 cycles Max.) Pre-heat : 100 ~ 120 °C, 30 ± 5 sec. Suggestion solder temp.: 235 ~ 255 °C, 10 sec. (Max.) Peak temp.: 260 °C</p> <p><u>Reflow soldering condition:</u> (2 cycles Max.) Pre-heat : 150 ~ 180 °C, 90 ~ 120 sec. Suggestion solder temp.: 235 ~ 255 °C, 20 ~ 40 sec. Peak temp.: 260 °C</p>  <p style="text-align: center;">Temperature profile for avaluation</p> <p><u>Hand soldering condition:</u> The soldering iron tip temperature should be less than 300°C and maximum contract time should be 5 sec.</p>

<b>Thick Film Chip Resistors (Terminal Lead Free)</b>		
7. Performance specification :		
Characteristics	Limits	Test Methods ( JIS C 5201-1 )
Soldering Heat	Resistance change rate is: $\pm(1\%+0.05\Omega)$ Max.	Dip the resistor into a solder bath having a temperature of $260^{\circ}\text{C}\pm 3^{\circ}\text{C}$ and hold it for $10\pm 1$ seconds. (Sub-clause 4.18)
Temperature cycling	Resistance change rate is $\pm (1.0\% + 0.05\Omega)$ Max.	Resistance change after continuous 5 cycles for duty cycle specified below :
		<b>Step</b> <b>Temperature</b> <b>Time</b>
		1 $-55^{\circ}\text{C} \pm 3^{\circ}\text{C}$ 30 mins
		2      Room temp.      10~15 mins
		3 $+155^{\circ}\text{C} \pm 2^{\circ}\text{C}$ 30 mins
		4      Room temp.      10~15 mins
		(Sub-clause 4.19)
Load life in humidity	Resistance change rate is $\pm (3.0\% + 0.1\Omega)$ Max.	Resistance change after 1,000 hours (1.5 hours "on", 0.5 hour "off" ) at RCWV in a humidity chamber controlled at $40^{\circ}\text{C} \pm 2^{\circ}\text{C}$ and 90 to 95 % relative humidity (Sub-clause 4.24.2.1)
Load Life	Resistance change rate is $\pm (3.0\% + 0.1\Omega)$ Max.	Permanent resistance change after 1,000 hours operating at RCWV, with duty cycle of (1.5 hours"on", 0.5 hour"off") at $70^{\circ}\text{C} \pm 2^{\circ}\text{C}$ ambient (Sub-clause 4.25.1)
Terminal bending	Resistance change rate is $\pm (1.0\% + 0.05\Omega)$ Max.	Twist of Test Board : Y/X = 5/90 mm for 10 seconds (Sub-clause 4.33)

### Thick Film Chip Resistors (Terminal Lead Free)

#### 8. Packing specification :

\* Taping Dimension (mm)

##### A. Paper taping

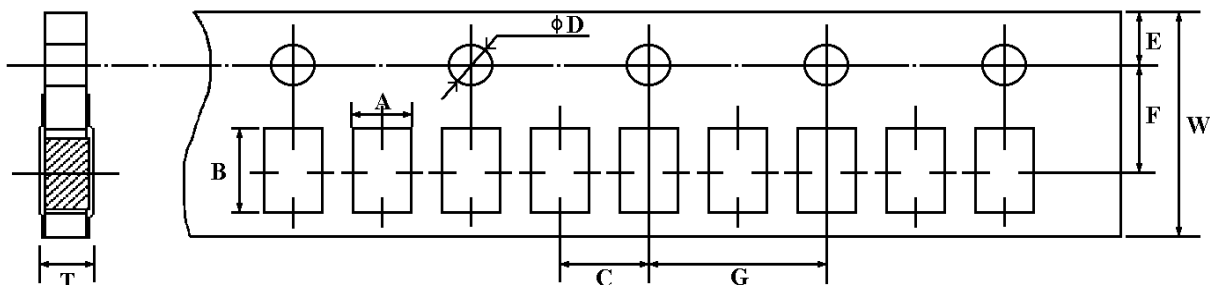

Type	A ± 0.05	B ± 0.05	C ± 0.05	ØD +0.1 - 0	E ± 0.1	F ± 0.05	G ± 0.1	W ± 0.2	T ± 0.1
RMC 0201	0.40	0.70	2.0	1.5	1.75	3.5	4.0	8.0	0.42

\* Reel Dimension (mm)

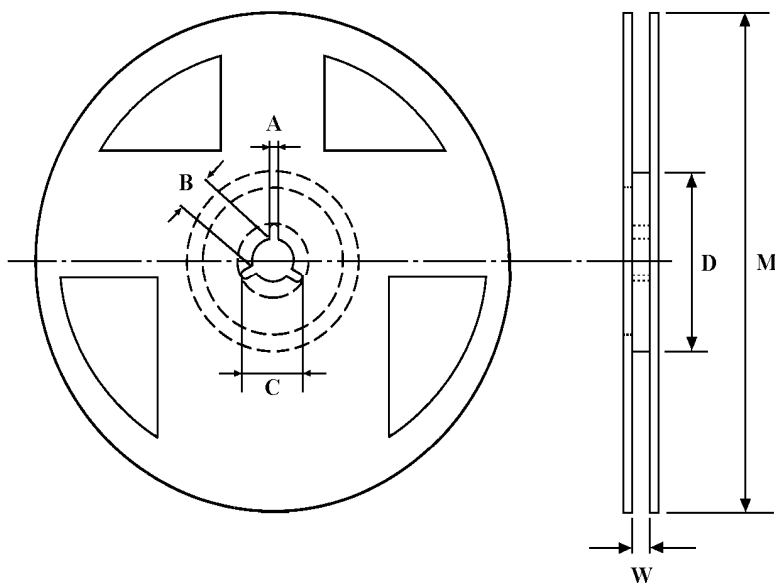

Type	Packaging	Quantity Per Reel	A ± 0.5	B ± 0.5	C ± 0.5	D ± 1	M ± 2	W ± 1
RMC 0201	Paper	10,000 pcs.	2	13	21	60	178	10



## Part Number System

### Explanation of Part Number System Thick Film Chip Resistors (Terminal Lead Free)

<b>1</b>	<b>2</b>	<b>3</b>	<b>4</b>	<b>5</b>	<b>6</b>	<b>7</b>	<b>8</b>	<b>9</b>	<b>10</b>	<b>11</b>	<b>12</b>	<b>13</b>	<b>14</b>
0	2	0	1	W	M	J	0	2	2	4	T	C	E

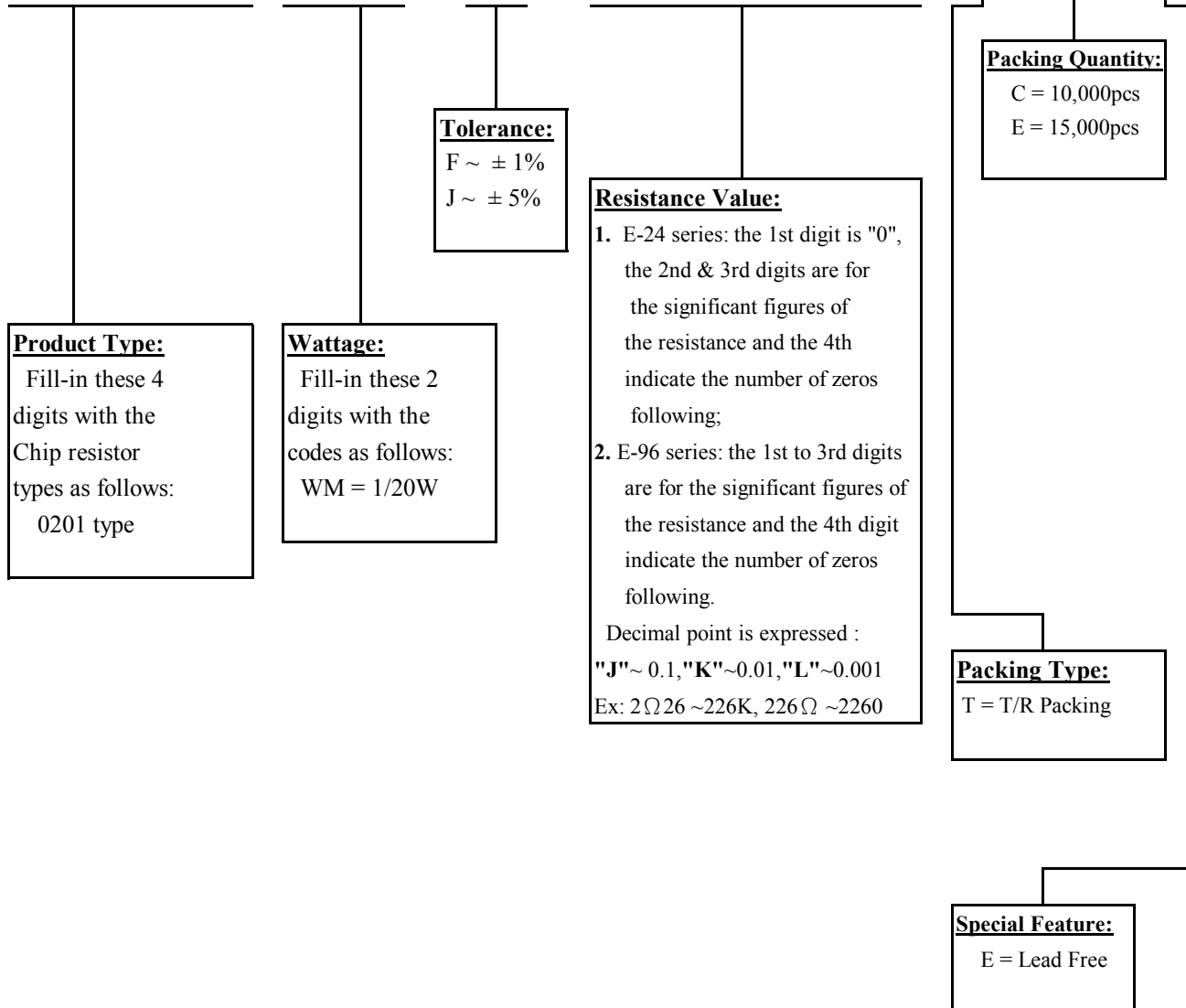

**Product Type:**  
Fill-in these 4 digits with the Chip resistor types as follows:  
0201 type

**Wattage:**  
Fill-in these 2 digits with the codes as follows:  
WM = 1/20W

**Tolerance:**  
F ~ ± 1%  
J ~ ± 5%

**Resistance Value:**

- E-24 series: the 1st digit is "0", the 2nd & 3rd digits are for the significant figures of the resistance and the 4th indicate the number of zeros following;
- E-96 series: the 1st to 3rd digits are for the significant figures of the resistance and the 4th digit indicate the number of zeros following.

Decimal point is expressed :  
"J"~ 0.1, "K"~0.01, "L"~0.001  
Ex: 2Ω26 ~226K, 226Ω ~2260

**Packing Quantity:**  
C = 10,000pcs  
E = 15,000pcs

**Packing Type:**  
T = T/R Packing

**Special Feature:**  
E = Lead Free

Sample : RMC 1/20W (0201) +/-5% 220KΩ T/R--10,000 → 0201WMJ0224TCE  
 RMC 1/20W (0201) +/- 5% 0Ω T/R--5000 → 0201WMJ000TCE

## **Thick Film Chip Resistors (Terminal Lead Free)**

### **Environment Related Substance**

This product complies to EU RoHS directive, EU PAHs directive, EU PFOS directive and Halogen free.

Ozone layer depleting substances.

Ozone depleting substances are not used in our manufacturing process of this product.

This product is not manufactured using Chloro fluorocarbons (CFCs), Hydrochlorofluorocarbons (HCFCs), Hydrobromofluorocarbons (HBFCs) or other ozone depleting substances in any phase of the manufacturing process.

### **Storage Condition**

The performance of these products, including the solderability, is guaranteed for a year from the date of arrival at your company, provided that they remain packed as they were when delivered and stored at a temperature of  $25^{\circ}\text{C} \pm 5^{\circ}\text{C}$  and a relative humidity of  $60\%\text{RH} \pm 10\%\text{RH}$

Even within the above guarantee periods, do not store these products in the following conditions. Otherwise, their electrical performance and/or solderability may be deteriorated, and the packaging materials (e.g. taping materials) may be deformed or deteriorated, resulting in mounting failures.

1. In salty air or in air with a high concentration of corrosive gas, such as  $\text{Cl}_2$ ,  $\text{H}_2\text{S}$ ,  $\text{NH}_3$ ,  $\text{SO}_2$ , or  $\text{NO}_2$
2. In direct sunlight